

# Clamping magnets

## Maximum adhesive force for safe processing

with unimagined production reserves

- ⌚ a 5-sided machining in one clamp
- ⌚ minimum set-up times and increase of productivity
- ⌚ increase of tool useful life and process safety

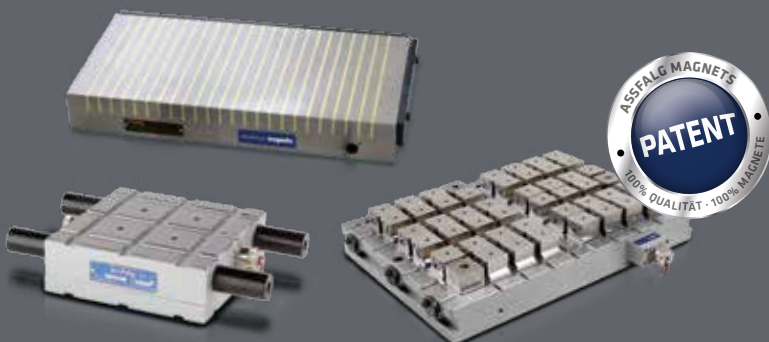

**assfalg**

**Assfalg GmbH**

Buchstraße 149  
73525 Schwäbisch Gmünd  
Germany

Tel +49 (0) 71 71.92 505-0  
Fax +49 (0) 71 71.92 505-50

info@assfalg-metal.com  
www.assfalg-metal.com

The right of changes and deviating pictures is reserved. Liability is excluded.

Design and production:  
Hela Werbung GmbH | www.hela.com

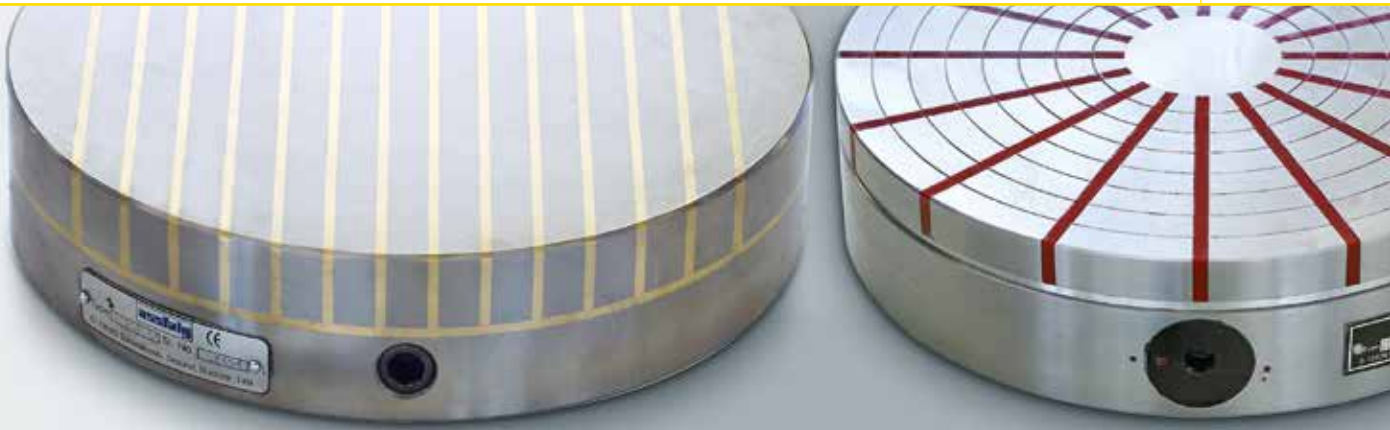

## Permanent Magnets



**Microfine**  
Permanent Magnetic Chucks

04



**Microsine**  
Permanent Magnetic Chucks

05



**Permamax**  
Permanent Magnetic Chucks

06



**Neostar**  
Permanent Magnetic Chucks

07

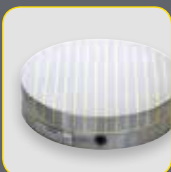

**Permamax**  
Permanent Magnetic Chucks

08

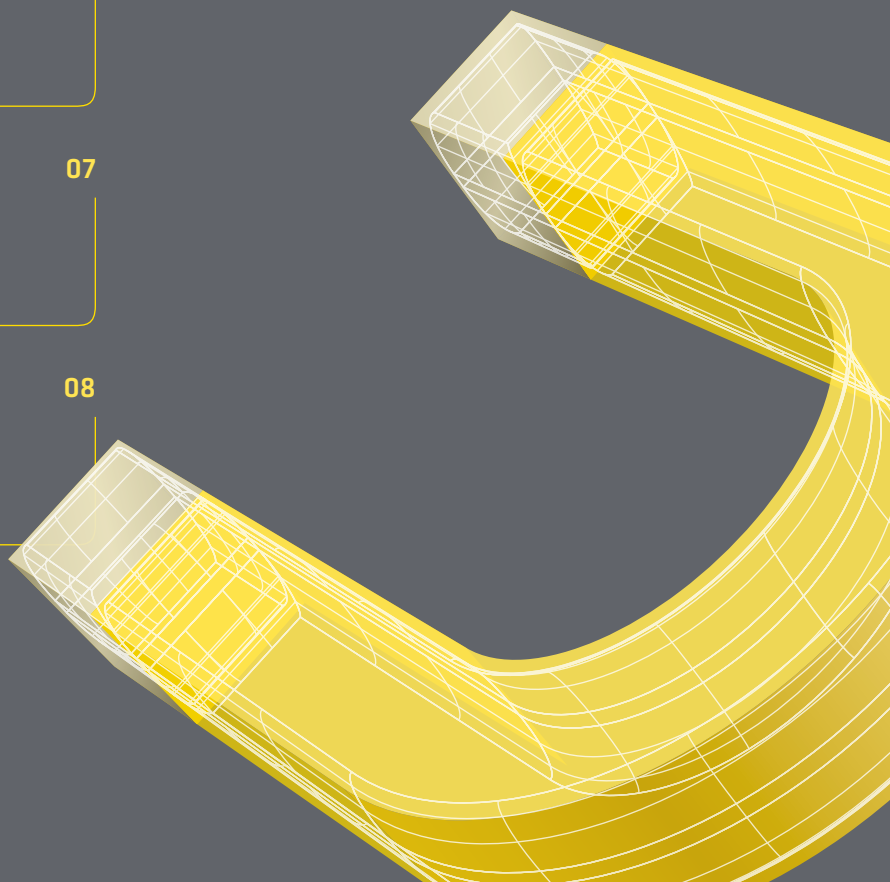



## Electropermanent Magnets | Magnet Welding Angles

09



**Magnaslot**  
Electropermanent  
Magnetic Chucks

10

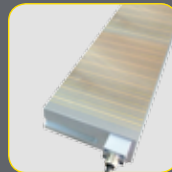

**EPFlux**  
Electropermanent  
Magnetic Chucks

20

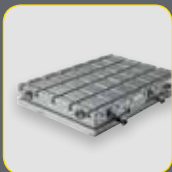

**Magnaslot mit T-Slots**  
Electropermanent  
Magnetic Chucks

14



**MS | SW | MAV | PA**  
Magnet Welding Angles

21



**Accessories**  
for Electropermanent Magnetic  
Chucks

15



**Magsquare**  
Magnetic module

22



**Doublemag | Triplemag**  
Electropermanent magnetic  
clamping elements

16



**A 90**  
Magnet Welding Angles

23

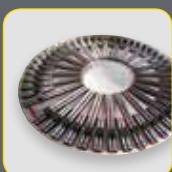

**Radialpol**  
Electropermanent  
Magnetic Chucks

18



**Boomer**  
Magnet Welding Angles, flexible

24



**Assfalg Clamping Magnets  
in use**

25

# Permanent Magnets

## How do Permanent Magnets function?

When switching on/off the Permanent Magnet System by operating a lever or similar, it will be spatially shifted in such a way that it will not be aligned under the poles any more. The magnetic flux will thereby be redirected inwards (📌 Graphic 1).

When switching on the system, a group of permanent magnets each will be aligned under the poles (📌 Graphic 2).

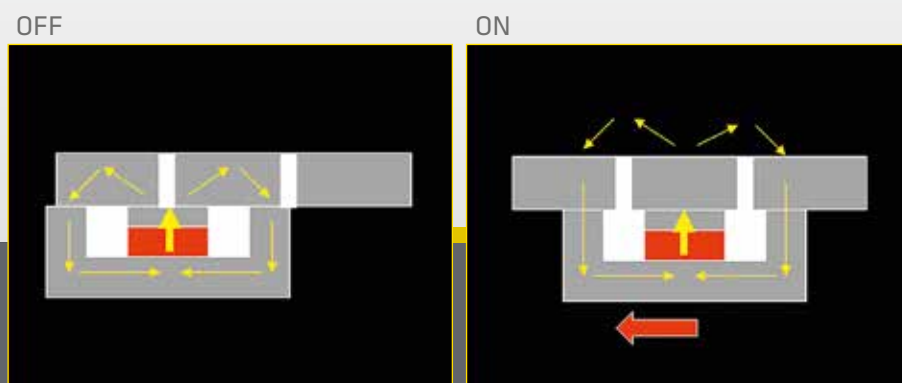

📌 Graphic 1

📌 Graphic 2

### Features

- ▶ Permanent Magnets are independent from any power source, portable and fail-safe
- ▶ The clamping force and size of a magnet system is limited by the internal mechanical friction
- ▶ A Permanent Magnet can be demagnetized by external, very large magnet fields or heat (> 80°C)



# Microfine

## Permanent Magnetic Chucks

The Microfine is an extremely economical Permanent Magnetic Chuck which can be manually switched.

It has a very flat magnetic field and is suitable for light and medium processing on machine tools.

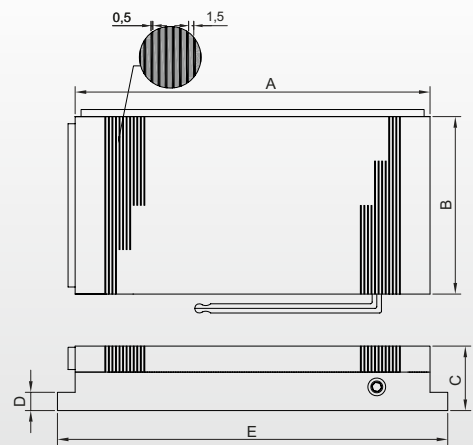
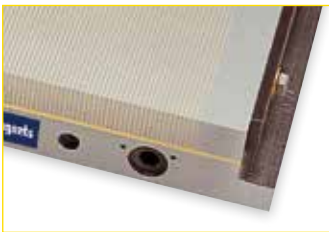

### Application

- ▶ Universally usable, especially for eroding and grinding works but also for fine milling
- ▶ For small and thin, but also for thick workpieces with a clean, flat surface

### Features

- Ⓛ Low design height with high adhesive force
- Ⓛ Processing of adhesive surface up to max. 8 mm depth
- Ⓛ Liquid-tight
- Ⓛ Can be switched ON/OFF mechanically
- Ⓛ Workpieces can be clamped stress-free and fast
- Ⓛ 5-side processing, as only one side is magnetically clamped
- Ⓛ Low penetration depth of the magnetic force because of a flat magnetic field due to fine pole pitch
- Ⓛ Adhesive force: 80 N/cm<sup>2</sup> with pole pitch 1.5 + 0.5 mm

### Technical data

	Dimensions [mm]					Weight	No.
	A	B	C	D	E	[kg]	
MF 1510	150	100	48	16	170	5	41731
MF 2512	250	125	48	16	270	11	41732
MF 3015	300	150	48	16	320	16	41733
MF 3515	350	150	48	16	370	18	1969
MF 4515	450	150	53	16	470	24	5093
MF 3020	300	200	53	16	320	22	17007
MF 4020	400	200	53	16	420	30	22221
MF 5020	500	200	53	16	520	37	39408
MF 5025	500	250	53	16	520	47	33730
MF 6030	600	300	58	16	620	76	32502

# Microsine

## Permanent Magnetic Chucks

Magnet Sinetables are very helpful for angle works on milling and grinding machines, particularly in tool making.

They are available in two versions: either single-pivotable via the longitudinal axis or double-pivotable via the longitudinal and transverse axis.

The mechanical Sinetables can be equipped with magnetic chucks as required.



### Application

- ▶ Universally usable, particularly for easy and medium milling and grinding works
- ▶ For small and thin, but also for thick workpieces with a clean, flat surface

### Features

- ☑ Liquid-tight
- ☑ The Sinetables are equipped with Microfine Magnetic Chucks as standard
- ☑ Low penetration depth of the magnetic force because of a flat magnetic field
- ☑ Processing of adhesive surface up to max. 8 mm depth
- ☑ Workpieces can be clamped in an angle, stress-free and fast
- ☑ Precise adjustment of the tilt angle using the sinus-table by means of gauge blocks
- ☑ All-around processing as only one side is clamped magnetically
- ☑ Adhesive force: 80 N/cm<sup>2</sup> with pole pitch 1.5 + 0.5 mm
- ☑ Swivel range 0 – 60°
- ☑ Surface hardened

### Technical data

	Dimensions [L×W] [mm]	No.	
		[pivotable around the longitudinal axis]	[pivotable around the longitudinal and transverse axis]
MF SI 1710	175 x 100	42461	42468
MF SI 3015	300 x 150	11045	27748
MF SI 4515	450 x 150	63101	63100
MS SI 6030	600 x 300	41795	on request
...	other sizes on request		

# Permamax

## Permanent Magnetic Chucks

The Permamax is an extremely strong Permanent Magnetic Chuck which is switched manually. It can be used universally on machine tools.

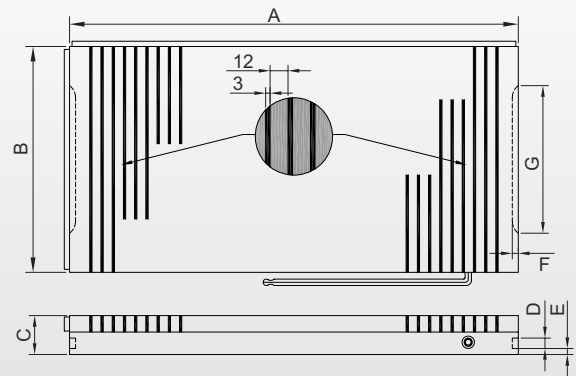
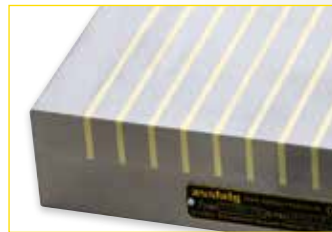
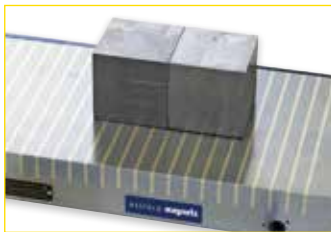

### Application

- ▶ Universally usable, especially for milling of small (from 30 × 15 × 6 mm) and big workpieces
- ▶ For thin, ferromagnetic workpieces from 0.8 mm thickness, as well as for thick workpieces

### Features

- Ⓜ Medium design height with very high adhesive force
- Ⓜ Processing of adhesive surface up to max. 8 mm depth
- Ⓜ Can be switched ON/OFF mechanically
- Ⓜ Workpieces can be clamped stress-free and fast
- Ⓜ 5-side processing, as only one side is magnetically clamped
- Ⓜ Low penetration depth of the magnetic force (approx. 10 mm) because of the flat magnetic field
- Ⓜ Adhesive force: 140 N/cm<sup>2</sup> with pole pitch 12 + 3 mm

### Technical data

	Dimensions [mm]							Weight [kg]	No.
	A	B	C	D	E	F	G		
PM 1610	160	100	52	14	12	8	60	6	57998
PM 2515	250	150	52	14	12	8	90	15	57999
PM 3015	300	150	52	14	12	8	90	18	5088
PM 3020	300	200	52	14	12	8	120	24	58000
PM 4020	400	200	52	14	12	8	120	32	58001
PM 6020	600	200	52	14	12	8	120	49	58002
PM 5030	500	300	52	14	12	8	190	61	58003
PM 6030	600	300	52	14	12	8	190	73	58005



# Neostar

## Permanent Magnetic Chucks

The Neostar is a very strong Permanent Magnetic Chuck with radial pole pitch. It is manually switched.

It is universally suitable for rotationally-symmetrical, ferromagnetic workpieces, especially for rings and discs from approx. 80 mm diameter.

A drilled hole in the center can be made.

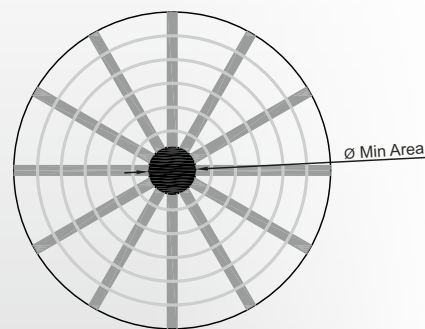
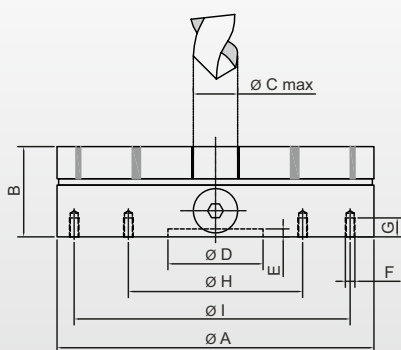
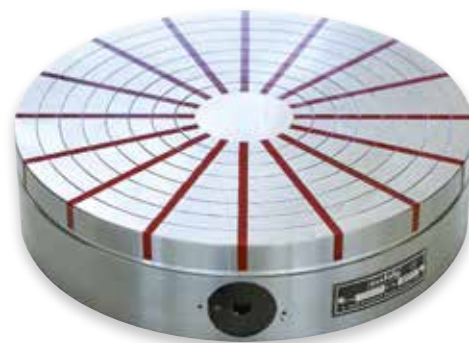

### Application

- ▶ Universally usable, particularly for internal cylindrical grinding, turning and hard turning
- ▶ Excellently suitable for clamping rings

### Features

- ✔ Medium design height with very high adhesive force
- ✔ Liquid-tight
- ✔ Can be switched ON/OFF mechanically
- ✔ The center is not magnetic and can be drilled up to the max. measure "C"
- ✔ Workpieces can be clamped stress-free and fast
- ✔ All-around processing as only one side is clamped magnetically
- ✔ A centric through-hole can be incorporated
- ✔ Low penetration depth of the magnetic force (approx. 10 mm) because of the flat magnetic field
- ✔ Adhesive force: 140 N/cm<sup>2</sup>

### Technical data

	Dimensions [mm]								Boreholes in F [mm]	Pole	Weight [kg]	No.
	A	B	C	D	E	G	H	I				
NS 13	130	57	20	50	5	12	-	100	4 x M6	10	6	4275
NS 16	160	57	24	50	5	12	80	120	4 x M6	10	9	5007
NS 20	200	57	30	60	5	12	110	180	4 x M6	12	14	16350
NS 25	250	70	42	80	5	12	140	220	4 x M6	16	27	12056
NS 30	300	73	42	150	6	16	180	260	4 x M8	16	41	37501
NS 35	350	73	56	170	6	16	220	300	4 x M8	20	55	37502
NS 40	400	75	56	200	8	16	260	340	4 x M8	20	75	37169
NS 50	500	81	75	200	8	16	300	400	4 x M10	24	125	37494
NS 60	600	95	100	250	8	20	350	450	4 x M12	30	200	57997

# Permamax

## Permanent Magnetic Chucks

The Permamax is a very strong Permanent Magnetic Chuck with parallel pole pitch. It is manually switched.

It is universally suitable for ferromagnetic workpieces, particularly for small parts and disks.

Only blind holes can be incorporated

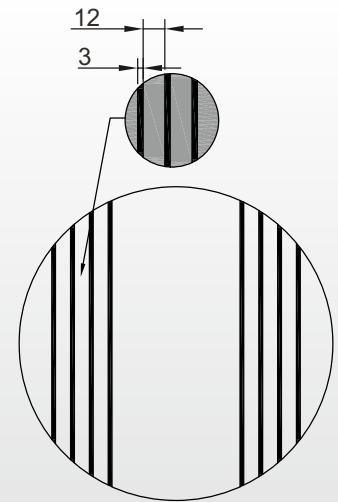
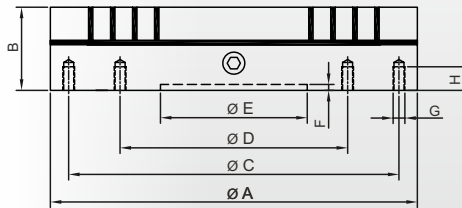
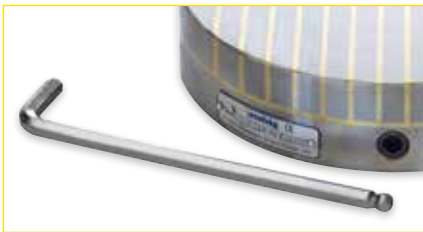

### Application

- ▶ Universally usable, particularly for small workpieces
- ▶ Best suitable for flat grinding, internal cylindrical grinding, turning and hard turning

### Features

- Ⓜ Medium design height with very high adhesive force
- Ⓜ Processing of adhesive surface up to max. 8 mm depth (5 mm at  $D \leq 130$  mm)
- Ⓜ Mechanically switchable
- Ⓜ Workpieces can be clamped stress-free and fast
- Ⓜ All-around processing as only one side is clamped magnetically
- Ⓜ Low penetration depth of the magnetic force (approx. 10 mm) because of the flat magnetic field
- Ⓜ Adhesive force:  $140 \text{ N/cm}^2$  with pole pitch  $12 + 3$  mm

### Technical data

	Dimensions [mm]								Weight [kg]	No.
	A	B	C	D	E	F	G	H		
PMR 10	100	55	-	75	50	5	M6	12	3	57990
PMR 16	160	55	120	80	50	5	M6	12	9	57991
PMR 20	200	55	180	110	60	5	M6	12	13	57992
PMR 25	250	55	220	140	80	5	M6	12	21	57993
PMR 30	300	55	260	180	150	6	M6	16	30	57994
PMR 35	350	55	300	220	170	6	M8	16	41	57995
PMR 40	400	55	340	260	200	8	M8	16	84	57996

# Electropermanent Magnets

## How do Electropermanent Magnets function?

Magnetic components (AlNiCo within the coil) which are controllable by means of current are magnetized using impulse current for a few seconds (👉 Graphic 1 + 2).

The magnetic components are exactly opposed to the polarizations of the Neodym Permanent Magnets, with the magnet being switched off (👉 Graphic 1). The magnetic components are rectified to the polarizations of the Neodym Permanent Magnets, with the magnet being switched on (👉 Graphic 2). **Electropermanent Magnets excel by their strong adhesion strength which they do not even lose in case of a power failure.**

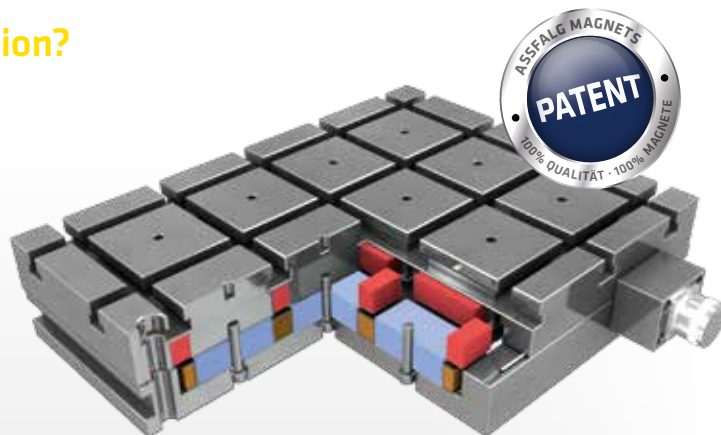

Patent No US 7999645

OFF

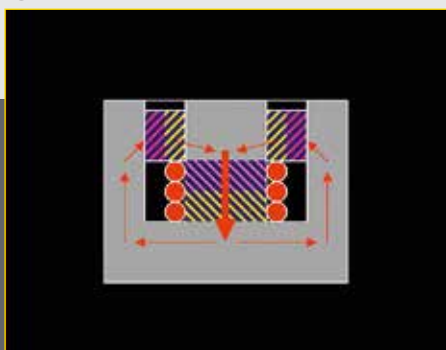

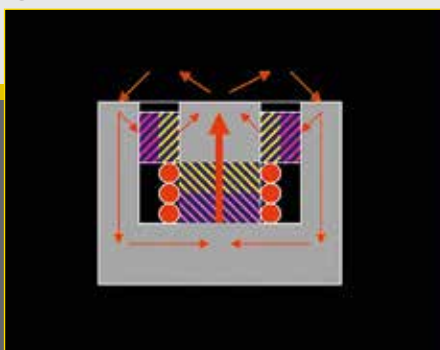

👉 Graphic 1

ON



👉 Graphic 2

 North pole  
 South pole

### Features

- ▶ Electropermanent Magnets combine both the Electrical and the Permanent Magnet Technology.
- ▶ It is a Permanent Magnet which is switched on and off electrically

# Magnaslot

Electropermanent Magnetic Chuck





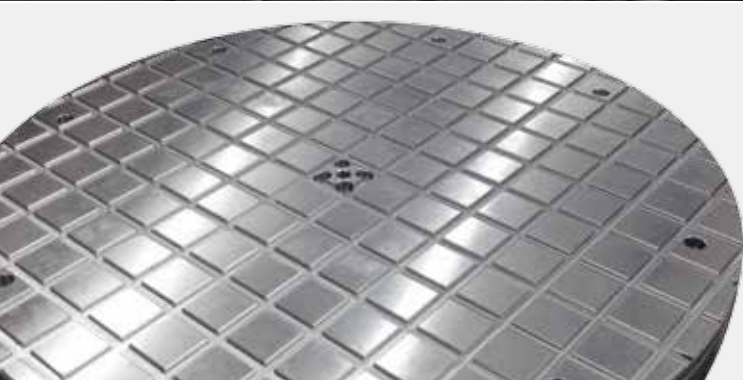

# Magnaslot

## Electropermanent Magnetic Chuck

The patented (EPM) electropermanent magnetic chuck with squarepole technology with a full steel surface is the perfect solution in clamping ferromagnetic workpieces on machine tools reliably and energy efficient. By using of pole extensions unevenness in the workpiece is being compensated and a distortion of the workpiece will be prevented.

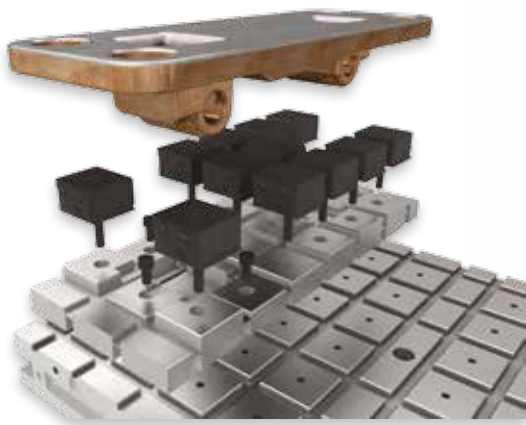

☺ Workpiece clamped on adapter plate mounted with mobile poles to adjust to the uneven surface

### Features [HD 50]

- ☑ Pole size 50 x 50 mm
- ☑ Adhesive force  $\geq 350$  kg per pole
- ☑ Penetration depth of the magnetic field at maximum of adhesive force level up to 12 mm
- ☑ A minimum of 8 poles contact is necessary for optimum clamping

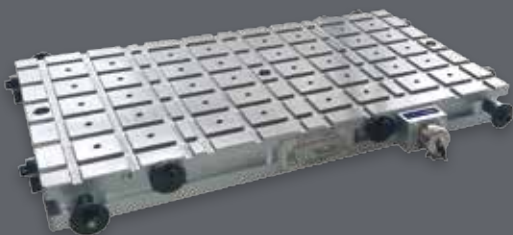

- ☑ Magnaslot 400 x 600 mm: ECO Version, 40 poles in pole sizes 50 mm offers enough adhesive surface for small and medium sized workpieces

### Technical data

	Dimension [LxWxH]	Number of Poles	Weight	No.
<b>High pole density (HD)</b>	[mm]		[kg]	
304 HD 50	300 x 430 x 55 *	24	50	38335
306 HD 50	300 x 590 x 55	32	72	50613
308 HD 50	300 x 750 x 55	40	91	41485
404 HD 50	420 x 430 x 55	36	71	49812
406 HD 50	420 x 590 x 55 *	48	100	56130
408 HD 50	420 x 750 x 55	60	127	48641
410 HD 50	420 x 990 x 55	84	168	49787
508 HD 50	480 x 750 x 55 *	70	145	50615
510 HD 50	480 x 990 x 55	98	192	50249
606 HD 50	600 x 590 x 55	72	143	50541
608 HD 50	600 x 750 x 55	90	181	49574
610 HD 50	600 x 990 x 55 *	126	240	49319
<b>Reduced pole density (ECO)</b>	[mm]		[kg]	
304 ECO 50	325 x 370 x 55	20	42	63276
406 ECO 50	370 x 635 x 55	40	90	63277
408 ECO 50	370 x 790 x 55	50	120	64066
608 ECO 50	580 x 790 x 55	80	170	63278

\* stock standard





- Magnaslot 400 x 600 mm: HD Version, 48 poles in pole sizes 50 mm offers enough adhensice surface for small and medium sized workpieces

- Magnaslot 400 x 800 mm: 32 poles pole size 75 mm



### Professional advantages

- ▶ All-around 5-sided machining is possible in one clamp
- ▶ No distortion by a hardly strained clamping of the workpiece
- ▶ Set-up times are reduced to a minimum, hence and increase of productivity
- ▶ Longer tool life and process accuracy
- ▶ Workpieces are clamped in seconds

Technical data	Dimension [L×W×H] [mm]	Number of Poles	Weight [kg]	No.
<b>High pole density (HD)</b>				
304 HD 75	327 x 425 x 60	12	62	48900
306 HD 75	327 x 601 x 60	18	87	49835
308 HD 75	327 x 815 x 60	24	118	52548
404 HD 75	415 x 425 x 60	16	78	52546
406 HD 75	415 x 601 x 60 *	24	110	49011
408 HD 75	415 x 815 x 60	32	150	49012
410 HD 75	415 x 1,029 x 60	40	188	50235
508 HD 75	503 x 815 x 60 *	40	181	52542
510 HD 75	503 x 1,029 x 60	50	228	49833
606 HD 75	591 x 601 x 60	36	157	52543
608 HD 75	591 x 815 x 60	48	212	52544
610 HD 75	591 x 1,029 x 60 *	60	268	49985

\* stock standard

### Features [HD 75]

- ▶ Pole size 75 x 75 mm
- ▶ Adhesive force  $\geq 790$  kg per pole
- ▶ Penetration depth of the magnetic field at maximum of adhesive force level up to 24 mm
- ▶ A minimum of 4 alternate poles contact is necessary for optimum clamping

### Options

- ▶ Controllers and pole extensions see accessories on page 15

### Application

- ▶ For clamping of small and big workpieces by milling processes
- ▶ Clamping without vibration and distortion
- ▶ Manufacturing and process accuracy with plane parallelism of 0.02 mm and more

# Magnaslot with T-Slots

## Electropermanent Magnetic Chuck

The patented (EPM) electropermanent magnetic chuck with T-Slots with a full steel surface combined the advantages of the magnetic and mechanical clamping in one chuck. It is the perfect solution in clamping ferromagnetic and non ferromagnetic workpieces on machine tools reliably and energy efficient.

By using of pole extensions unevenness in the workpiece is being compensated and a distortion of the workpiece will be prevented.

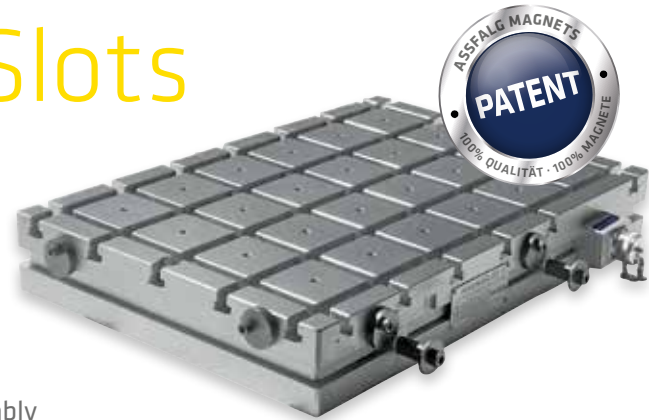

### Application

- ▶ All-around 5-sided machining is possible in one clamp
- ▶ For clamping of small and big workpieces by milling processes and rough and fine precision machining
- ▶ Clamping of magnetic and nonmagnetic workpieces
- ▶ A combination of multiple EPM chucks enable a processing of big workpieces

### Features

- Ⓜ Pole size 75 x 75 mm
- Ⓜ T-slots for the mechanical clamping
- Ⓜ Adhesive force  $\geq 790$  kg per pole
- Ⓜ Penetration depth of the magnetic field at maximum of adhesive force level up to 25 mm
- Ⓜ Completely from a full steel body, hence the best protection against hot chips and coolant
- Ⓜ By using pole extensions also uneven workpieces can be clamped without distortion
- Ⓜ Minimization of setup times

### Options

- Ⓜ Controllers and pole extensions (see accessories on page 15)

Technical data	Dimension [LxWxH] [mm]	Number of Poles	Weight	No.
			[kg]	
304 HD 75T	327 x 425 x 93	12	90	48887
406 HD 75T	415 x 601 x 93	24	160	49010
508 HD 75T	503 x 815 x 93	40	250	51870
610 HD 75T	591 x 1,029 x 93	60	370	49986

# Accessories

## For Electropermanent Magnetic Chucks

The function of the electronic controllers reserving the polarity is to switch on and off the magnetic chuck and for regulating the adhesive force in 8 steps by the corresponding manual control unit. If several or multiple chucks are grouped together a distributor JB is switched between. For a magnetic chuck size of 600 x 600 mm the controller D50 is enough. For bigger sizes the controller D100 is required. Every controller is provided with a 3 m power cable for connection to 400 V and with a 3.5 m power cable with bayonet connection for each channel.



Controller D50



Hand operating unit



PVF



PVB Pole extension compressed (left) and in a rebounding state (right)

Technical data	Pole size	Dimensions	Version	No.
Pole extensions [Typ]	[mm]	[mm]		
PVF 50	50	50 x 50 x 32	fixed	61262
PVB 50	50	50 x 50 x 32	mobile	61263
PVF 75	75	75 x 75 x 48	fixed	40127
PVB 75	75	75 x 75 x 48	mobile	40128

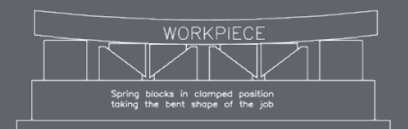
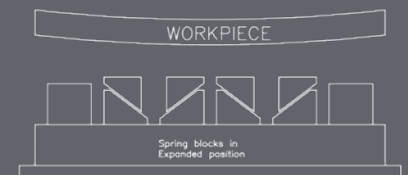

Technical data	Channel	No.
Controller [Typ]		
EPM-D50 to 50 A, with remote and adhesive regulation	1	64200
EPM-D100 to 100 A, with remote and adhesive regulation	1	52950
EPM-D100-4 to 100 A, with remote and adhesive regulation	4	58088
EPM-D100-6 to 100 A, with remote and adhesive regulation	6	60875



4-channel- operator panel for D100-4

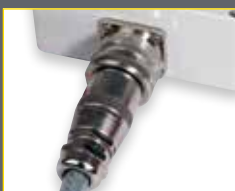

Bayonet connection



Bayonet socket



Bayonet plug

# Doublemag | Triplemag

## Electropermanent Magnetic Chucks

These magnetic modules are adhesive on both sides and both clamp the work piece and themselves to the machine table. Mechanical clamping or fix clamping is not required.

Several modules combined, are a cost-effective alternative to big magnetic chucks.

The Triplemag series has additional positioning magnets, ensuring a constant position on the machine table and which are separately switched.



DM 502

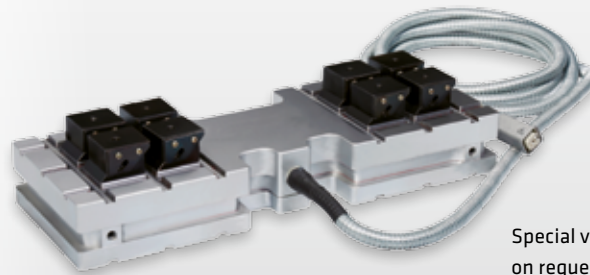

TM 505

Special versions  
on request

### Application

- ▶ For clamping big or bulky workpieces during milling processing, rough or finish machining
- ▶ For clamping during edge cutting or deburring (without mechanical chucks)
- ▶ For simple and fast fixing of workpieces during mounting
- ▶ Also usable with fixed and movable pole extensions for uneven surfaces

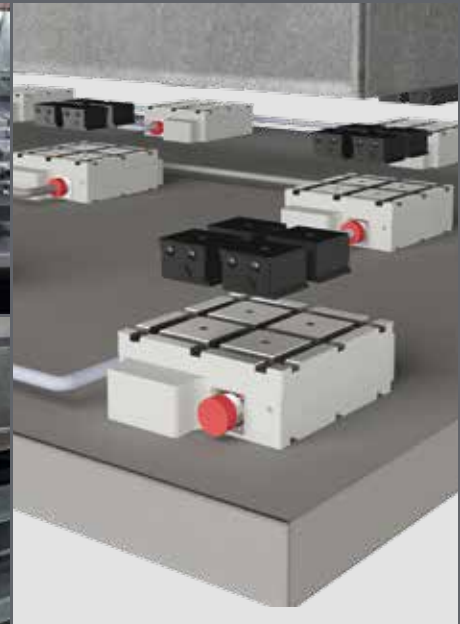



- Several Doublemags together

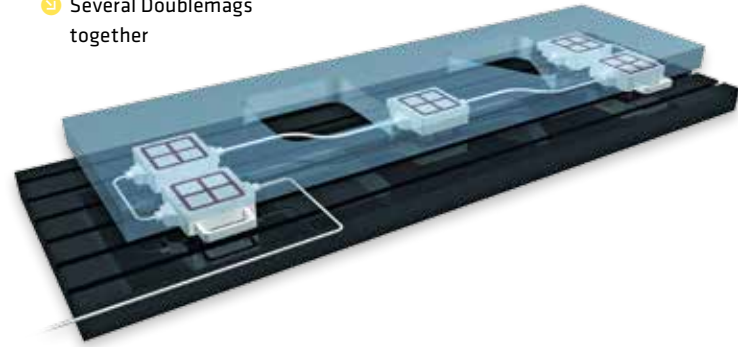

### Professional advantages

- ▶ Drastic reduction of set-up times
- ▶ A 5-sided processing at simple and fast positioning of the work piece
- ▶ Low vibration while milling, and even distribution of adhesive force over the entire magnetic clamping surface
- ▶ For processing big parts, several Double/Triplemags can be connected with each other and controlled
- ▶ Using pole extensions, plane-parallelism of up to 0.01 mm is possible on the work piece
- ▶ Also bulky workpieces can be clamped without distortion by using pole extensions
- ▶ Full utilization of the machine, because there are no disturbing edges unlike with mechanical clamping

### Features

- ✔ Pole size 50 × 50 mm
- ✔ Adhesive force ≥ 350 kg per pole
- ✔ Penetration depth of the magnetic field at maximum adhesion force up to 12 mm
- ✔ Complete full steel body, so the best protection against hot chips and coolant
- ✔ Full clamping force will only be achieved if the supporting table is ferromagnetic and at least 15 mm thick

### Options

- ✔ For pole extensions see Accessories on page 15



Controller D40-S

### Technical data

	Dimensions [L×W×H] [mm]	Number of poles	Voltage [Volt]	Ampere [A]	Weight [kg]	No.
DM 502	180 x 180 x 52	2 x 4	220	4	12	52186
TM 503	220 x 180 x 52	2 x 4 + 1 x 2	220	4	12	51991
TM 505	340 x 100 x 52	2 x 4 + 1 x 2	220	4	13	57086



# Radialpol

## Electropermanent Magnetic Chuck

The Electropermanent Magnet Chuck from Assfalg is ideal for clamping big, rotationally-symmetrical workpieces from 400 mm diameter without distortion.

A drilled hole in the center can be made at any time.

Pole extensions which are attached to the surface of the magnetic chuck make it possible also for uneven workpieces or raw parts to be clamped without distortion.



🕒 EPRadial from Ø 600 mm



### Application

- ▶ Universally suitable for clamping ferromagnetic (ferrous) workpieces, particularly on lathes and disc grinding machines
- ▶ Ideal for bearing ring processing, also for hard processing

🕒 EPRadial-P to Ø 600 mm

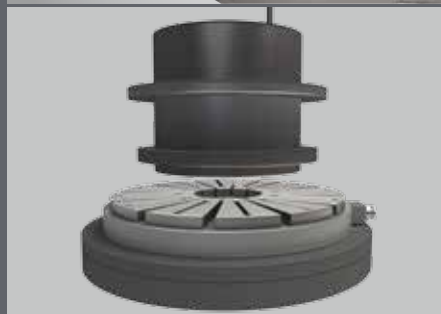





### Professional advantages

- ▶ Extremely short set-up times due to simple and fast clamping of workpieces
- ▶ 5-side processing, as only one work piece side is required for magnetic clamping
- ▶ Distortion-free holding of raw part or uneven work piece, because positive-locking clamping by means of fixed and mobile pole extension becomes possible (underlining of workpieces is not necessary any more!)
- ▶ No damages to the magnetic chuck in case of breakouts, because the work piece can be clamped raised to pole extensions
- ▶ Slight adjustment of the magnetic adhesion power to thin workpieces or when aligning by means of the adhesion power regulation

### Features

- ⌚ Extremely high, permanent, magnetic adhesion power at activation within seconds
- ⌚ Through holes or surrounding clamping slots for fastening on machine table or device
- ⌚ Special cable with bayonet fixing or fixed cable with slip ring carrier enable a connection of magnetic chuck and controller

### Options

- ⌚ Optionally, the magnetic chuck can be also delivered with T-slots so that additional stops can be fixed
- ⌚ For controllers and pole extensions see Accessories on page 15

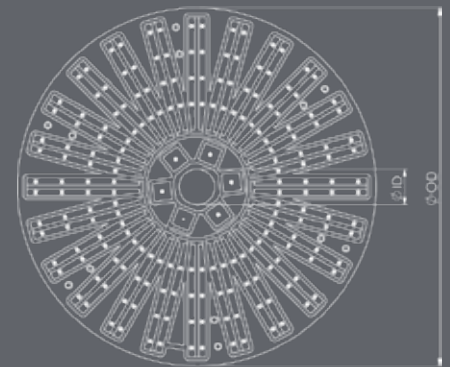

### Technical data

	External diameter	Internal diameter	Height	No.
	[mm]	[mm]	[mm]	
EPRadial 600	600	200	90	65047
EPRadial 800	800	250	90	63541
EPRadial 1000	1,000	250	90	on request
EPRadial 1250	1,250	500	90	on request
...	other sizes on request			

# EPFlux

## Electropermanent Magnetic Chuck

The EPFlux magnetic chuck is highly suitable for grinding application of all size of jobs – also for hardened and alloyed workpieces, because there is nearly no residual magnetism. By the EPM technology no heat built up. This guarantees a maximum of precision while processing.

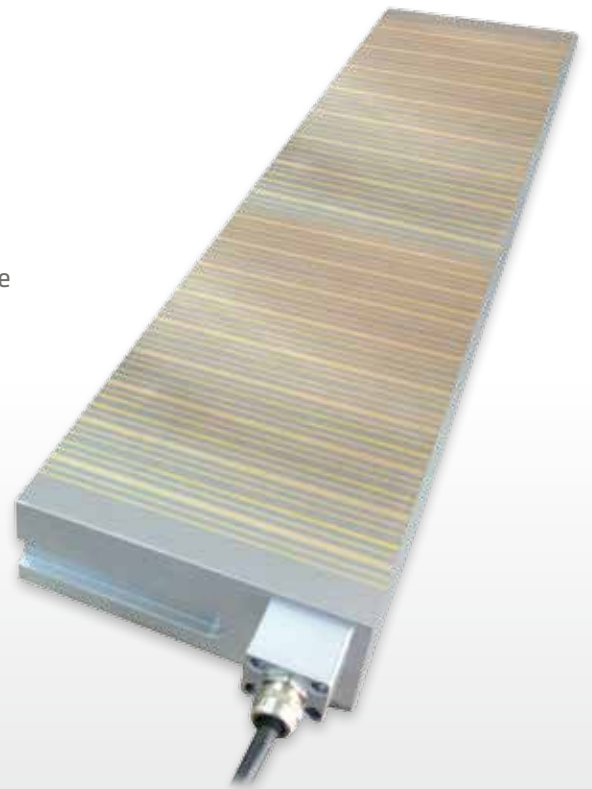

### Features

- ⌚ Clamping force approx. 100 N/cm<sup>2</sup>
- ⌚ Pole pitch 5 + 1.5 mm
- ⌚ Incorporating cable outlet
- ⌚ Controlling and switching with the controller D50-F/D100-F 220 V / 400 V depending on the size of the chuck

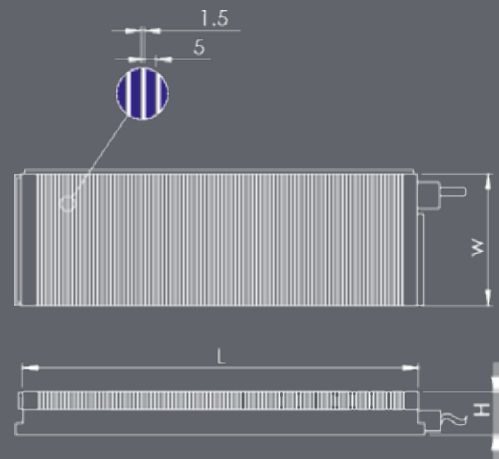

### Technical data

Technical data	Length	Width	Height	No.
	[mm]	[mm]	[mm]	
EPFlux 4515	450	150	65	64287
EPFlux 5020	500	200	65	51002
EPFlux 6030	600	300	65	63494
EPFlux 8040	800	400	65	on request
EPFlux 10050	1,000	500	65	on request
EPFlux 15060	1,500	600	65	on request

# MS | SW | MAV | PA

## Magnet Welding Angles

Your universal handyman for small welding and assembly works, for round and flat materials. All magnetic angles are switchable and suitable for flat and round material, except SW.

MAV 120 and PA 200 are stepless angle adjustable.



MS



PA 200



SW



MAV 120



MSA

### Features

- ☑ Easy positioning, adjusting and fixing of workpieces
- ☑ No disruption of the arc when welding
- ☑ MS, MAV 120 and PA 200 each thigh is switchable
- ☑ MAV 120 and PA 200 have an easy and exactly angle adjustment by a quick release and scale



Technical data	Dimensions [LxWxH] [mm]	Angle	Switchable	Use also for Round material	Adhesive force [kg]	Weight [kg]	No.
MSA I	110 x 30 x 95	45°/90°	Yes	Yes	36	0.7	45338
MSA II	150 x 35 x 130	45°/90°	Yes	Yes	60	1.4	45339
MS 2-80	153 x 38 x 153	90°	Yes *	Yes	46	1.2	48192
MS 2-90	195 x 59 x 195	90°	Yes *	Yes	68	2.7	18736
MAV 120	197 x 50 x 197	25° - 275°	Yes *	Yes	41	2.4	162
PA 200	240 x 41 x 240	22° - 270°	Yes *	Yes	90	1.6	60343
SW 200	200 x 50 x 200	90°	No	No	40	2.5	46504
SW 300	300 x 50 x 300	90°	No	No	60	4.0	46503

\* Every thigh is separately switchable

# Magsquare

## Magnetic module

Universal welding and mounting help. The magnetic force acts on 3 sides. It can also be used as an addition to magnetic angle A 90 and Boomer. Several threaded holes already exist as fastening options.



## Features

- ⌚ Magnets can be completely switched off by just turning the switch lever by 180°
- ⌚ Usable for round and square workpieces
- ⌚ Retention force acts on all sides
- ⌚ Threaded holes on every side for individual take-up or mounting

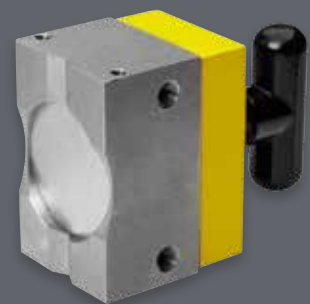

## Technical data

Technical data	Dimensions [L×W×H]	Adhesive force	Weight	No.
	[mm]	[kg]	[kg]	
MSQ 165	48 x 31 x 65	68	0.3	61939
MSQ 400	64 x 42 x 90	181	0.9	60971
MSQ 600	75 x 52 x 106	272	1.4	60972
MSQ 1000	72 x 108 x 147	454	3.4	60973

# A 90

## Magnet Welding Angles

Your third indispensable hand for welding or assembly works on flat and round materials at an angle of 90°.



### Features

- ☑ Magnets can be completely switched off by just turning the switch lever by 180°
- ☑ Sturdy steel construction of the angle
- ☑ Usable as inside and outside angle
- ☑ Usable for round and square workpieces
- ☑ Even more magnetic force with optional extensible magnetic modules

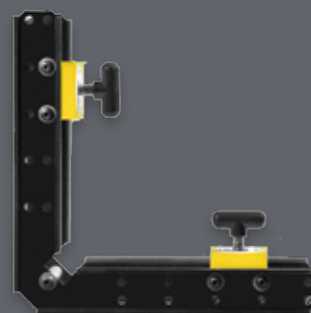

### Technical data

	Dimensions [LxWxH]	Adhesive force	Weight	No.
	[mm]	[kg]	[kg]	
A 165	205 x 47 x 205	68	0.8	61945
A 400	288 x 104 x 288	181	2.8	60340
A 600	288 x 134 x 288	272	3.7	60341
A 1000	287 x 145 x 474	454	4.6	60342



# Boomer

## Magnet Welding Angles, flexible

Your compact helper for welding or assembly works, for round and flat materials.



### Features

- ⌚ Fast and easy angle adjustment by means of quick release
- ⌚ Engraved scales for exact angle adjustment, 0 - 360°
- ⌚ Magnets can be completely switched off by just turning the switch lever by 180°
- ⌚ Sturdy steel construction of the angle
- ⌚ Usable for round and square workpieces
- ⌚ Retention force acts on all sides



### Technical data

	Dimensions [LxWxH]	Adhesive force	Weight	No.
	[mm]	[kg]	[kg]	
BA 150	196 x 80 x 196	68	1.3	60344
BA 400	257 x 109 x 257	181	3.0	60345
BA 600	257 x 169 x 257	272	4.4	60346



# Assfalg Clamping Magnets

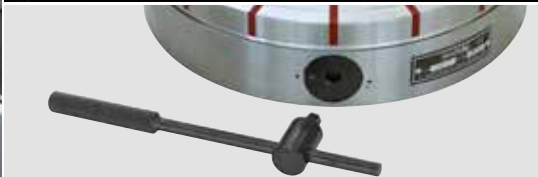
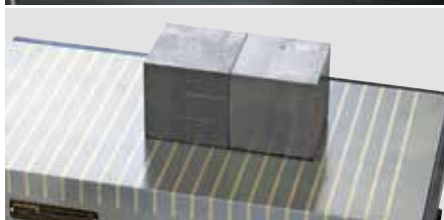
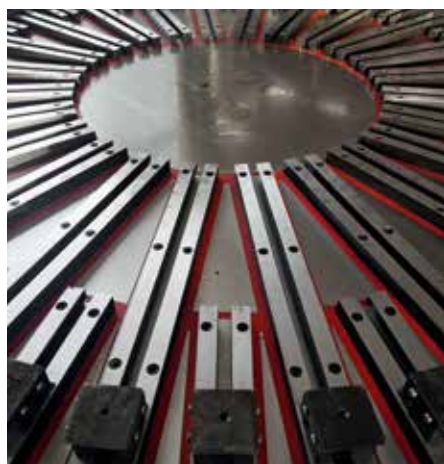
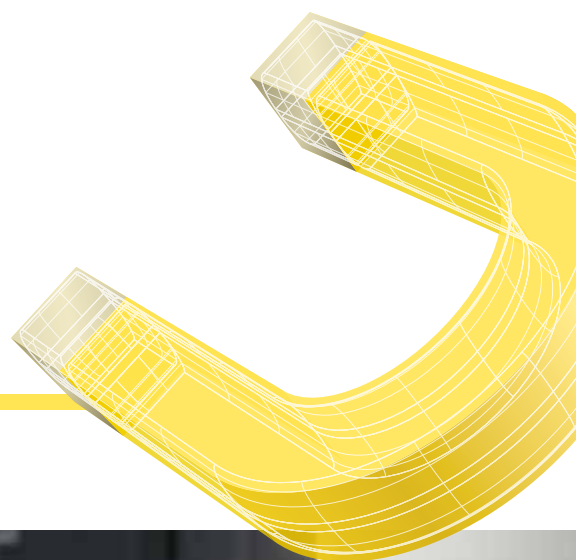

WANT TO KNOW MORE?

**We advise you gladly.  
Via telephone or during a personal appointment.**

➤ T +49 (0) 71 71.92 505-0    ➤ [info@assfalg-metal.com](mailto:info@assfalg-metal.com)



[www.assfalg-metal.com](http://www.assfalg-metal.com)

**Assfalg GmbH**

Buchstraße 149  
73525 Schwäbisch Gmünd  
Germany

Tel +49 (0) 71 71.92 505-0

Fax +49 (0) 71 71.92 505-50

**assfalg**